

Section One: Short answers

30% (54 Marks)

This section has **12** questions. Answer **all** questions. Write your answers in the space provided.

When calculating numerical answers, show your working or reasoning clearly. Give final answers to three significant figures and include appropriate units where applicable.

When estimating numerical answers, show your working or reasoning clearly. Give final answers to a maximum of two significant figures and include appropriate units where applicable.

Spare pages are included at the end of this booklet. They can be used for planning your responses and/or as additional space if required to continue an answer.

- Planning: If you use the spare pages for planning, indicate this clearly at the top of the page.
- Continuing an answer: If you need to use the space to continue an answer, indicate in the original answer space where the answer is continued, i.e. give the page number. Fill in the number of the question(s) that you are continuing to answer at the top of the page.

Suggested working time: 50 minutes.

Question 1

[4 marks]

Calculate the distance above the Earth's surface a satellite must be placed in order to remain in a geostationary orbit.

Question 2

[3 marks]

A spherical 2.00 kg ball is moving down an inclined which has a slope of 30.0° as shown in the diagram below. Calculate the normal (reaction) force provided by the plane on the ball.

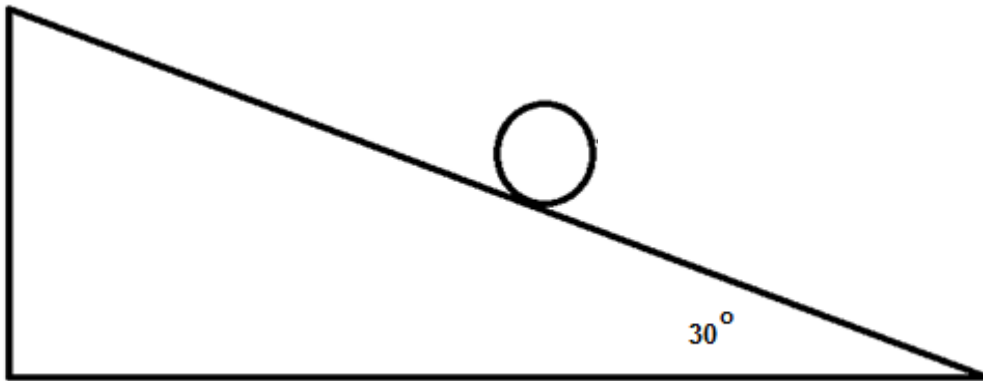

Question 3

[5 marks]

A mass spectrometer is used to calculate the mass of charged particles. In one such machine ${}^3_2\text{He}^{2+}$ and ${}^4_2\text{He}^{2+}$ nuclei in a beam travelling at a velocity of $5.11 \times 10^6 \text{ m s}^{-1}$ enter a region with a magnetic field density of $5.21 \times 10^{-1} \text{ T}$ as shown in the diagram below:

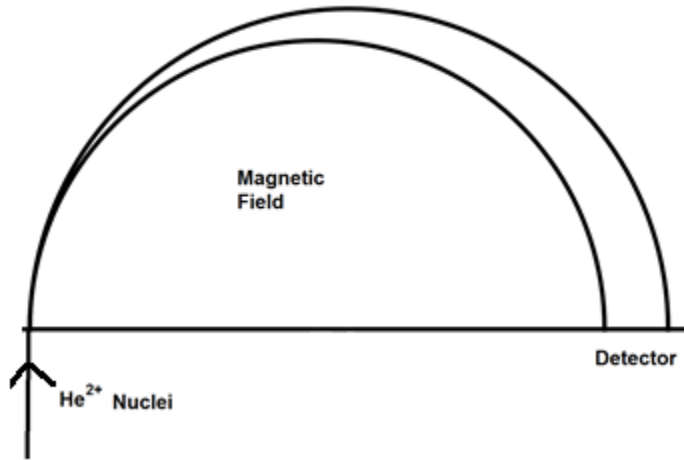

Circle the option below which gives the correct direction of the magnetic field: (1 mark)

Up Down Left Right Into the page Out of the page

Place a "4" on the path followed by the ${}^4_2\text{He}^{2+}$ nuclei. (1 mark)

Calculate the mass of a ${}^4_2\text{He}^{2+}$ nucleus given that the radius of its path is $2.01 \times 10^{-1} \text{ m}$. (3 marks)

Question 4**[7 marks]**

The volume of a hydrogen atom is $1.99 \times 10^{-31} \text{ m}^3$. Assume the atom is a sphere and the electron travels along its surface.

Volume of a sphere $V = \frac{4}{3}\pi r^3$

Calculate the following forces between the proton and the electron:

a) Gravitational force.

(4 marks)

b) Electromagnetic force.

(2 marks)

c) Net force.

(1 mark)

Question 5**[4 marks]**

Juliette (43.2 kg) decided to build a seesaw using a 4.12 m uniform beam. She was accompanied by her friend, Julian (61.2 kg) and her sister, Georgina (21.6 kg). If the pivot is placed at the centre of the seesaw, calculate where each person could sit in order to create an equilibrium where the seesaw is level. Include a sketch of your strategy as part of your answer.

Question 6

[4 marks]

On the following diagram, draw the electric field lines. Draw at least ten lines.



Question 7**[7 marks]**

A roller coaster with three passengers has a mass of 9.73×10^2 kg. The participants experience being upside down at the top of the circular track of a “loop the loop” showground ride. The centre of mass of the roller coaster and passengers is 15.3 m from the bottom of the ride. It is travelling at a constant speed of 12.3 m s^{-1} .

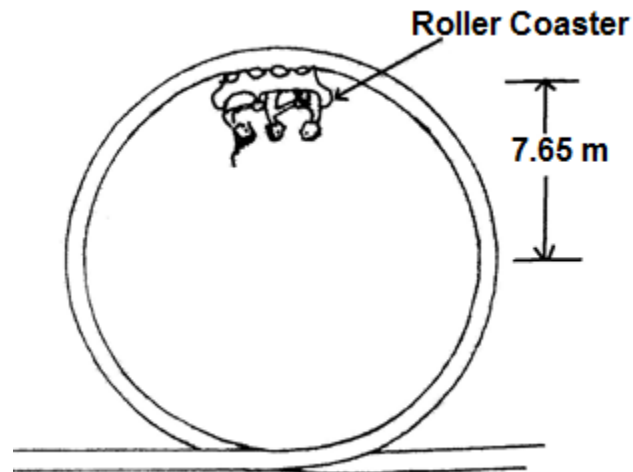

- a) Calculate the magnitude of the force that the rails at the top of the ride exerts on the coaster plus passengers. (5 marks)
- b) On the diagram above, draw labelled vectors to indicate the real forces acting on the coaster plus passengers. (2 marks)

Question 8

[5 marks]

An electric beater is used to make bread dough of the right consistency. The bread dough was too thick and the beater jammed. Explain why the insulation of the coil in the electric motor melted.

Question 9

[4 marks]

A horseshoe magnet rests on a top-pan balance with a 10.0 cm long wire situated between the poles of the magnet as shown below:

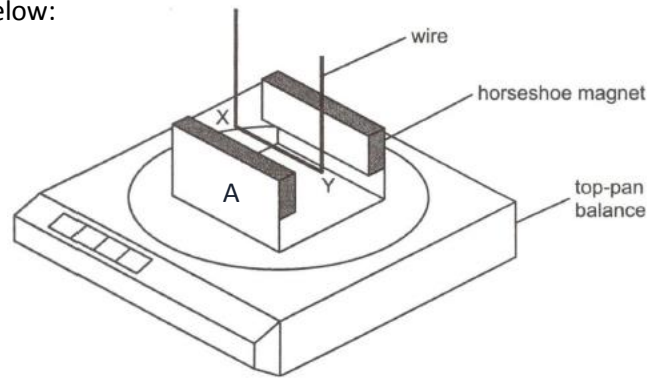

With no current in the wire, the reading on the balance is 142.0 g.

With a current of 2.00 A in the wire in the direction XY, the reading on the balance changes to 144.6 g.

- a) State the polarity of the pole of the magnet marked 'A'. (1 mark)

- b) Calculate the magnetic field density between the poles of the magnet. (3 marks)

Question 10

[5 marks]

A narrow vertical rectangular coil is suspended from the middle of its upper side with its plane at an angle of θ to a uniform horizontal magnetic field of 0.0500 T as shown below. The coil has 50 turns, and the lengths of its vertical and horizontal sides are 0.200 m and 0.100 m respectively. Calculate the magnitude and direction of the torque on the coil when the angle of θ is 25.0° and a current of 5.00 A is passed into it.

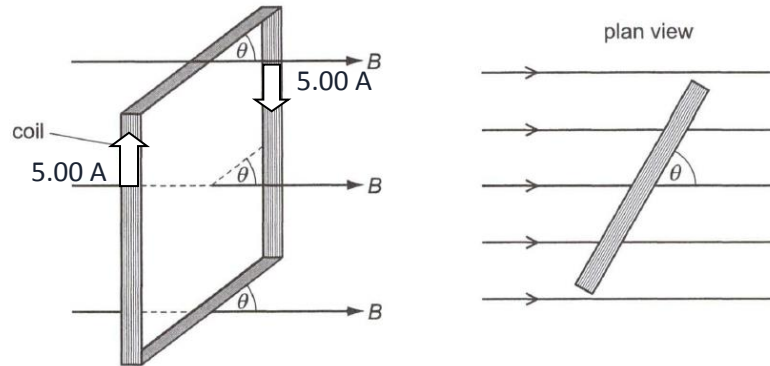

Question 11**[4 marks]**

Two small charges A and B are 10.0 cm apart. The charges are such that A is $+3.00 \times 10^{-9}$ C and B is -1.00×10^{-9} C. Calculate the vector force on the charge at A due to B.

Question 12**[5 marks]**

GPS satellites orbit the Earth at an altitude of 2.02×10^5 km above the Earth's surface. They have an issue in that the weaker gravitational field strength at this altitude causes times to speed up on the satellite relative to time on the Earth. Calculate the gravitational field strength that the Earth exerts on the satellite.

Section Two: Problem-solving**50% (90 Marks)**

This section has six **(6)** questions. You must answer **all** questions. Write your answers in the space provided.

Spare pages are included at the end of this booklet. They can be used for planning your responses and/or as additional space if required to continue an answer.

- Planning: If you use the spare pages for planning, indicate this clearly at the top of the page.
- Continuing an answer: If you need to use the space to continue an answer, indicate in the original answer space where the answer is continued, i.e. give the page number. Fill in the number of the question(s) that you are continuing to answer at the top of the page.

Suggested working time for this section is 90 minutes.

Question 13**[14 marks]**

Two six-year-old children sit next to each other with their shoulders touching.

- a) Estimate the gravitational force between them. (3 marks)

- b) Draw the gravitational field of one of the children (use at least 6 field lines). (3 marks)

Question 13 (cont'd)

- c) One of these two children climbs on top of a shelf that is one metre above the ground. Estimate the child's total mechanical energy when they are standing upright on the shelf. (3 marks)

- d) The child in part c) steps off the shelf. When their centre of mass is 0.700 m above the ground estimate their velocity and kinetic energy. (3 marks)

- e) Estimate how much work was done on the child when it reached the ground. (2 marks)

Question 14

[17 marks]

An induction heater consists of a solenoid of radius 15.0 cm in the base of the unit driven by a high frequency electricity supply. An induction pan has a solid iron base which behaves as a flat circular coil. An expanded view is shown below.

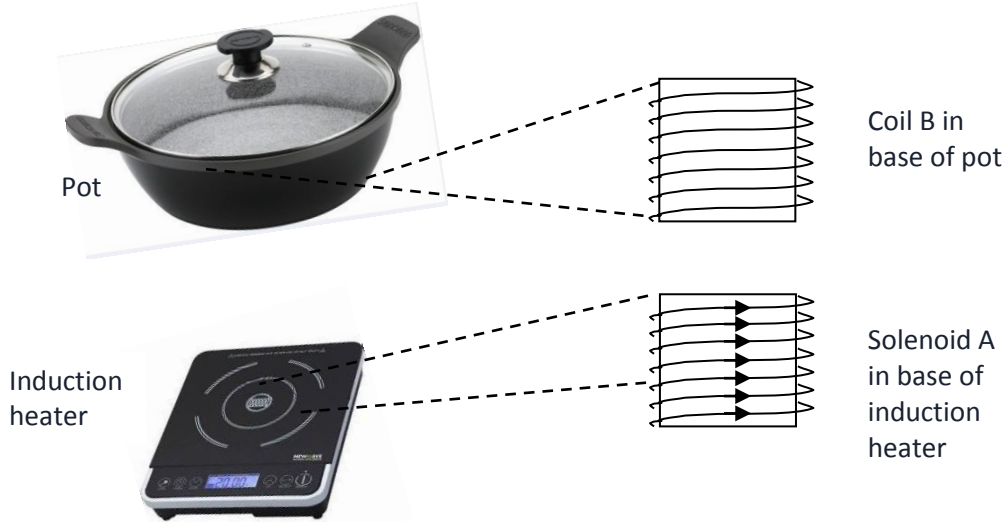

- a) The current in solenoid A is continuously changing due to the high frequency electricity supply. At a particular instant, the current is increasing to a value of 10.0 A in the direction shown. On the diagram of solenoid A below, sketch the shape and direction of the magnetic field produced. (2 marks)

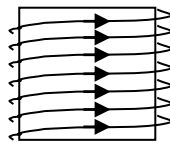

- b) At that same instant, an EMF is induced in coil B. Explain this phenomenon. (3 marks)

- c) Indicate, using arrows, the direction of the induced current in coil B. (1 mark)

Question 14 (cont'd)

- d) Stating Lenz's law, explain how you derived the direction of the induced current in coil B. (4 marks)
- e) The flat circular coil in the base of the pot has a diameter of 15.0 cm and 500 turns. At a given instant, the flux density linking the coils is 20.0 mT. The flux density is reduced to zero and then increased to 20.0 mT in the opposite direction at a constant rate. The time taken for the whole operation is 60.0 ms.
- i) Calculate the flux linking the coils. (2 marks)
- ii) Calculate the EMF generated in coil B. (3 marks)
- iii) Assuming coil B has a resistance of 0.500 ohm, calculate the power generated. (2 marks)

Question 15**[10 marks]**

At the centre of the Milky Way is a black hole known as Sagittarius A. It has a mass equivalent to 4.31 billion Suns. It is 26 500 light years from the Sun. A light year is the distance light would travel in one year.

- a) Calculate the gravitational force between the black hole and the Sun. (3 marks)
- b) Use the force calculated in part a) to calculate the orbital speed of the Sun around the black hole. If you were unable to answer part a) you may use a value for gravitational force between the black hole and the Sun of 1.75×10^{20} N for this part of the question. (3 marks)

Question 15 (cont'd)

- c) Assuming a circular orbit. Scientists have determined that the Sun moves around the black hole with a speed of $2.20 \times 10^2 \text{ km s}^{-1}$. Calculate the centripetal force involved in creating this orbit. (2 marks)

- d) The values for force in parts a) and c) are not the same due to different assumptions made by scientists in determining the values involved in the calculations. State two assumptions which might be used to account for this discrepancy. (2 marks)

Question 16

[16 marks]

A yacht is moored in a marina being prepared for the Sydney to Hobart race. The uniform boom is 13.0 m long and is attached to the mast 1.50 m above the deck. The boom is held at an angle of 5.0° above the horizontal by a cable. A 50.0 kg weight is attached at the free end of the boom by another light cable to prevent sudden movement. The cables may be considered massless in your calculations.

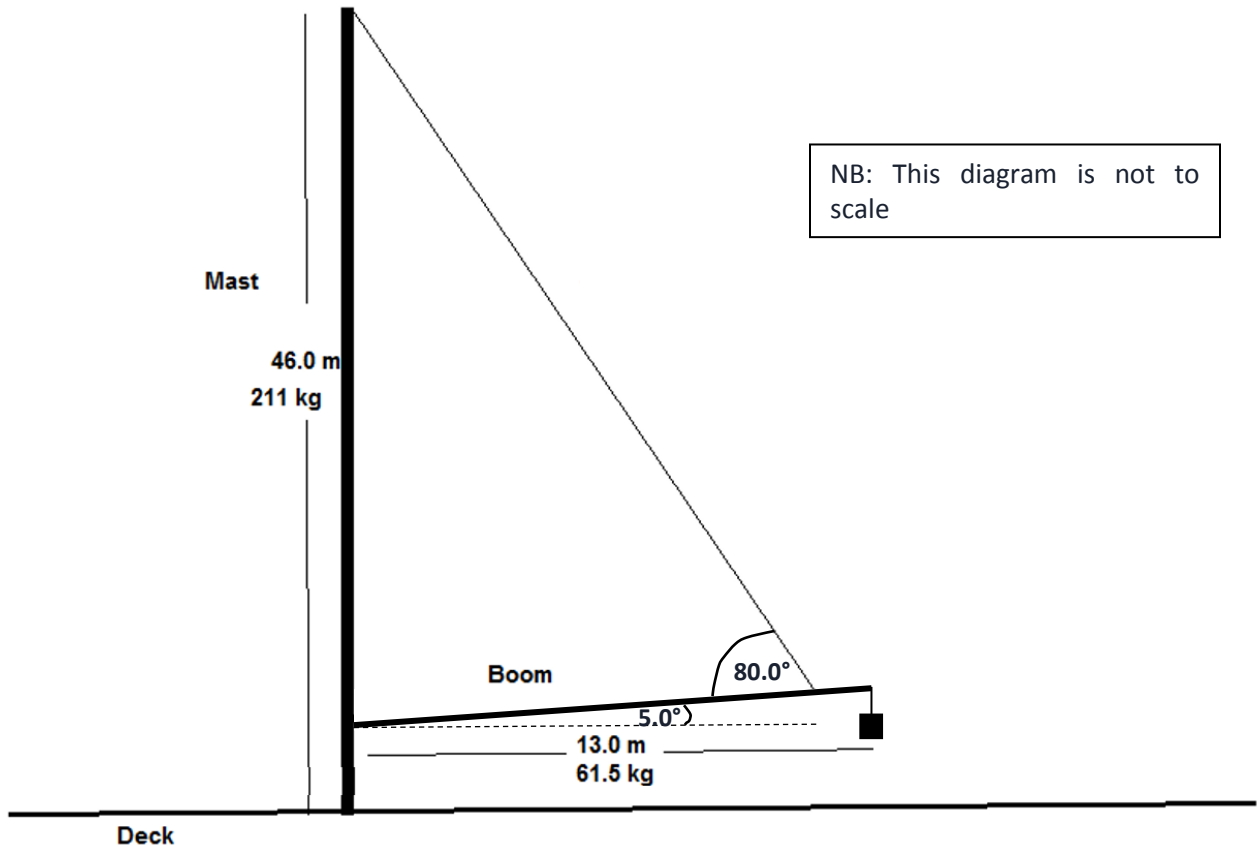

- a) Draw a free body diagram of the boom, showing all forces acting on it.

(4 marks)

Question 16 (cont'd)

b) Calculate the tension in the cable.

(7 marks)

Question 16 (cont'd)

c) Calculate the reaction force exerted by the mast on the boom.

(5 marks)

Question 17

[17 marks]

The Perth Wildcats basketball team is two points down with 10 seconds to go until the end of the game, and Nat Jawai has the ball in centre court. He puts up the shot and scores three points.

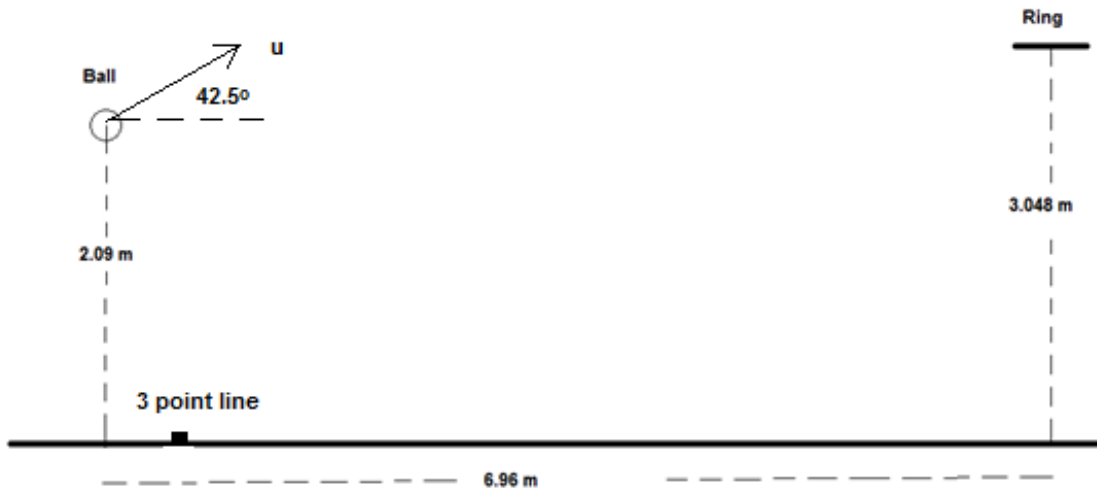

- a) In the space below draw a diagram of the ball showing the force/s acting on it whilst in flight. Assume no air resistance. (2 marks)

- b) He propels the ball at an angle to the horizontal of 42.5° . Calculate the initial speed of the ball? (6 marks)

Question 17 (cont'd)

- c) Calculate the velocity as it passes through the ring in order to score the three points required to win the game. (If you were unable to calculate the initial velocity in part a) you may use an initial velocity of 8.90 m s^{-1} in your calculations for this part of the question)
- (7 marks)

Question 17 (cont'd)

- d) The diagram below shows the path of the ball including the effects of air resistance. Draw the path the ball would take if it was launched at the same height and initial velocity, but if there was no air resistance. (2 marks)

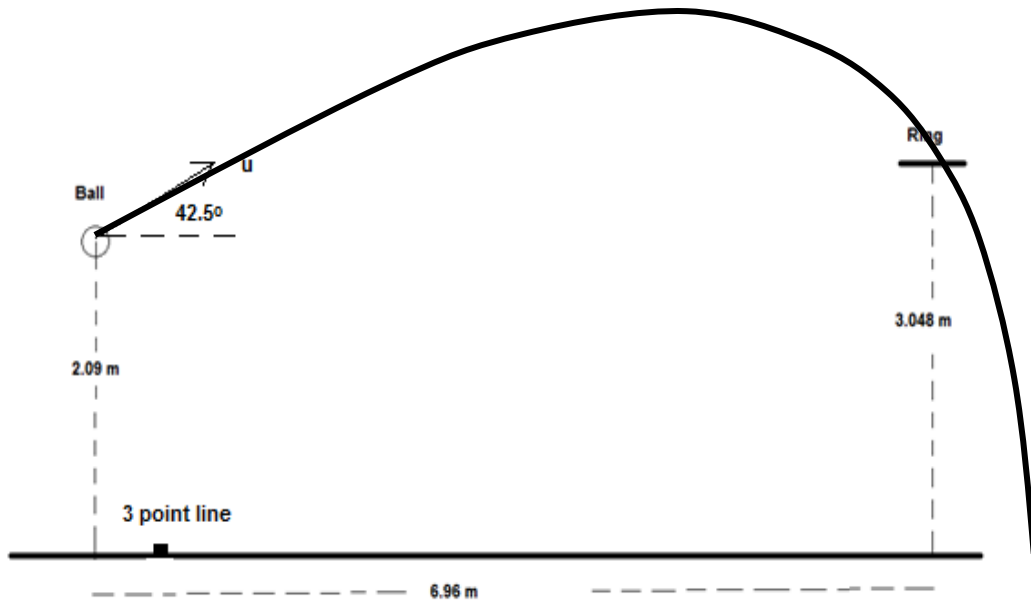

Question 18

[14 marks]

Two parallel charged plates are set up as in the diagram below.

- a) Draw the electric field between the plates. (3 marks)



- b) A proton is fired, with a velocity of $8.67 \times 10^7 \text{ m s}^{-1}$, into the space between the 0.500 m long plates as shown below. The plates are 20.0 mm apart and the potential difference between the plates is $3.00 \times 10^3 \text{ V}$. The experiment is placed vertically to the ground and the proton is effected by gravity.

Calculate the total force acting on the proton as it travels between the plates and indicate the path of the proton as it passes between the plates. (4 marks)

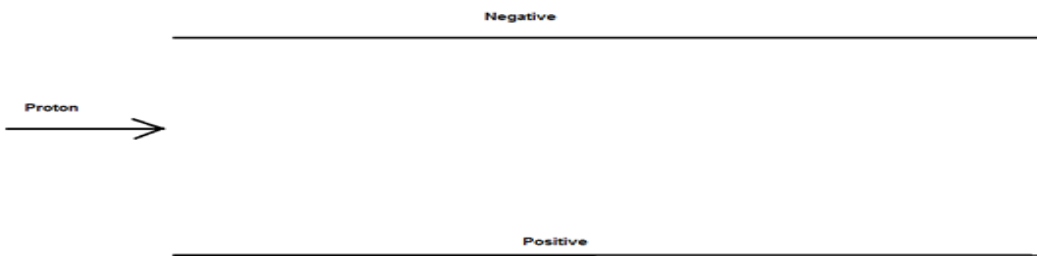

Question 18 (cont'd)

c) Calculate the velocity at which the proton leaves the gap between the plates. (5 marks)

d) Calculate the vertical displacement of the proton whilst it is between the plates. (2 marks)

Section Three: Comprehension

20% (36 Marks)

This section contains two (2) questions. Answer **both** questions. Write your answers in the space provided. Spare pages are included at the end of this booklet. They can be used for planning your responses and/or as additional space if required to continue an answer.

- Planning: If you use the spare pages for planning, indicate this clearly at the top of the page.
- Continuing an answer: If you need to use the space to continue an answer, indicate in the original answer space where the answer is continued, i.e. give the page number. Fill in the number of the question(s) that you are continuing to answer at the top of the page.

Suggested working time for this section is 40 minutes.

Question 19

[18 marks]

Edison and Tesla, two great scientists found themselves on the opposite sides of the debate whether to use DC (Edison) or AC (Tesla).

Edison to prove his point that AC was too dangerous electrocuted an elephant and advocated that AC be used for the electric chair. Further he built 121 DC power stations in the United States of America. The Boulder power station in the Goldfields of Western Australia was originally a DC power station. Unfortunately, users of this power had to be within 2 km of the station.

AC power could be readily converted from low to high voltages and back again so it could be transferred long distances with lower energy losses.

Much of our electronics today use DC power and when the AC is converted to DC about 3% energy is lost in the form of heat. Also LEDs which use DC suffer from flicker which reduces their lives, and solar panels produce DC current which is converted to AC using inverters. DC can now be converted to high voltages relatively easily and voltages for transmission of up to 800 kV have been achieved.

An issue with high voltage is the “skin effect” which means that at high voltages the current travels on the outside of the wire which effectively increases the resistance of the wire. This then requires that more expensive multi-strand wires are required to transmit the power.

Further many places use UPSs (Uninterruptable Power Supplies) which convert AC to DC (batteries) then back to AC and then back to DC to run the electronics.

Should we convert our power supplies to DC which is safer, much of our electronics use DC already and much of the green energy produced is DC and would be more compatible with a DC grid.

On the reverse many of our appliances are AC based and our power stations are all built to provide AC. Converting them would be a huge expense.

The South/West power grid operated by Western Power extends from Kalbarri (600 km North of Perth) to Ravensthorpe (530 km SE of Perth) across to the coast, with an extension to Kalgoorlie.

Question 19 (cont'd)

Synergy is the electricity generator and retailer for the grid. They charge domestic customers 23.36630 cents per unit. A unit is a kilowatt hour.

A power station can generate 6.00×10^2 MW of energy at 30.0 kV. This is then sent to a sub-station where the voltage is increased to 3.30×10^2 kV. This is then transported at that voltage over large distances. It then comes to a series of sub-stations that step down the voltage to 33.0 kV, then 11.0 kV, 6.00 kV and finally about 4.00×10^2 V. Each transformer stage loses approximately 1.00% (ie 99% efficient).

The power is distributed from the last sub-station as three phase power down the streets. Most houses opt for one phase ($\sim 2.40 \times 10^2$ V) at a frequency of 50.0 Hz.

Large voltage wires are usually multi-strand aluminium cables surrounding an iron core which provides the tensile strength. The resistance of the wire is $1.02 \times 10^{-4} \Omega \text{ m}^{-1}$.

- a) Explain why multi-strand wires are used in large voltage power lines. (2 marks)
- b) Calculate the energy lost in transmitting 3.30×10^2 kV AC electricity from the generator to sub-station 1 to a town which is 151 km away. (7 marks)

Question 20**[18 Marks]**

Many everyday examples of machines rely on circular motion. Satellites for weather observations, GPS, communications and monitoring activities is one such group. Some others include spin dryers in washing machines, separating blood samples into its components in a centrifuge, and mass spectrometers.

Centrifugal force does not exist in an inertial frame of reference and is generally considered to be a “mythical” or inertial force. In the past, it was sometimes defined as the reaction force to the centripetal force.

Centrifugal is based on the Latin word which means flight (moving away from centre), centripetal comes from the Latin for seeking (moving towards centre).

A satellite orbiting the Earth in a circular orbit is always falling towards the Earth yet maintains the same altitude.

Rockets are used to place satellites in their respective orbits. Satellites that are designed to have orbits parallel to Earth’s equator are generally launched in an easterly direction from the east coast close to the equator.

Geostationary satellites are usually launched in this manner. These satellites are a significant reason that we can receive continuous TV signals from the other side of the world. Pay TV companies also use geosynchronous satellites as well as cable to provide services to their customers. They are also valuable in weather services as each satellite monitors a set part of the Earth’s surface.

Question 20 (cont'd)

An experiment to demonstrate the forces involved in circular motion is set up as follows:

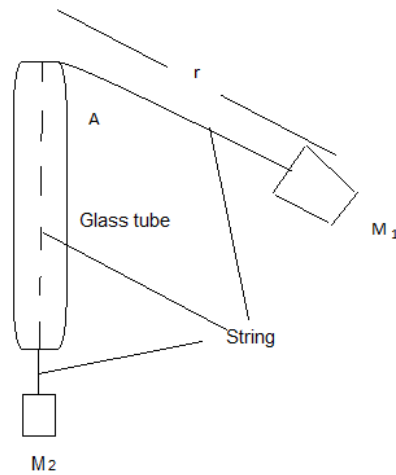

A student holds the glass tube and swings the rubber stopper (M_1) in a horizontal circle maintaining a constant radius. The force (tension in the string) is provided by a mass (M_2) which can be varied. Another student measures the time taken for 25 revolutions.

The following is a set of results for one such experiment.

M_1 has a mass of 38.3 g

r is 61.3 cm

Trial #	Force of M_2 (N)	Time for 25 revolutions (s)	Period (s)	Velocity ² ($\text{m}^2 \text{s}^{-2}$)	Error in v^2 (10%)
1	0.50	32.4	1.30	8.8	0.9
2	1.50	18.5			
3	2.50	15.5			
4	3.50	12.3			
5	4.50	11.0			
6	5.50	10.3			

- a) Complete the three incomplete columns (the first row has been done for you). (3 marks)

Question 20 (cont'd)

- b) Plot the data including error bars for each data point. (A spare sheet of graph paper is provided at the end of this paper if required. (4 marks)

TITLE: Force and velocity² graph

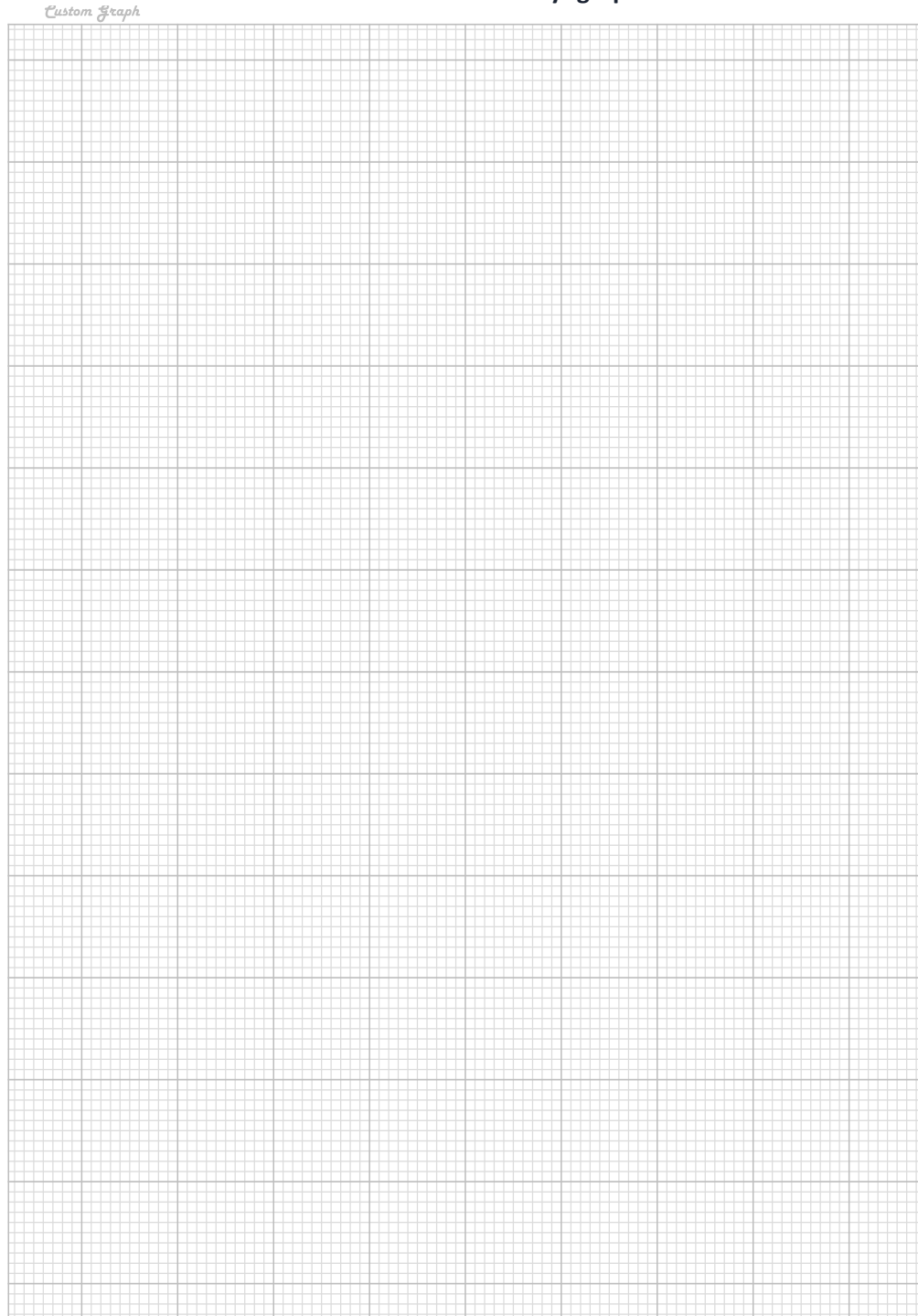

Question 20 (cont'd)

- c) Plot a line of best fit. (2 marks)
- d) Using the line of best fit, calculate the gradient of $F \propto v^2$. (2 marks)
- e) No matter how fast you can reasonably make M_1 travel, it will never have a horizontal string. Explain. (1 mark)
- f) A satellite that is constantly falling can maintain a circular path around the Earth at a constant altitude. Use a diagram help to explain why this occurs. (3 marks)

Question 20 (cont'd)

- g) With the aid of a diagram, explain why it is that a satellite which is in a circular orbit around the Earth, must have the centre of its orbital plane directly above the centre of mass of the Earth.

(2 marks)

- h) A satellite can use a jet of propellant to adjust its orbit if required. Explain how it is possible for this to work in the near vacuum of space?

(1 mark)

END OF EXAM